

ACME THREAD  
5-3/4 MAJOR THREAD  
5-3/8 MINOR THREAD  
9/16 PITCH

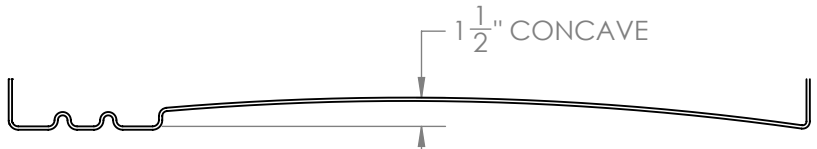
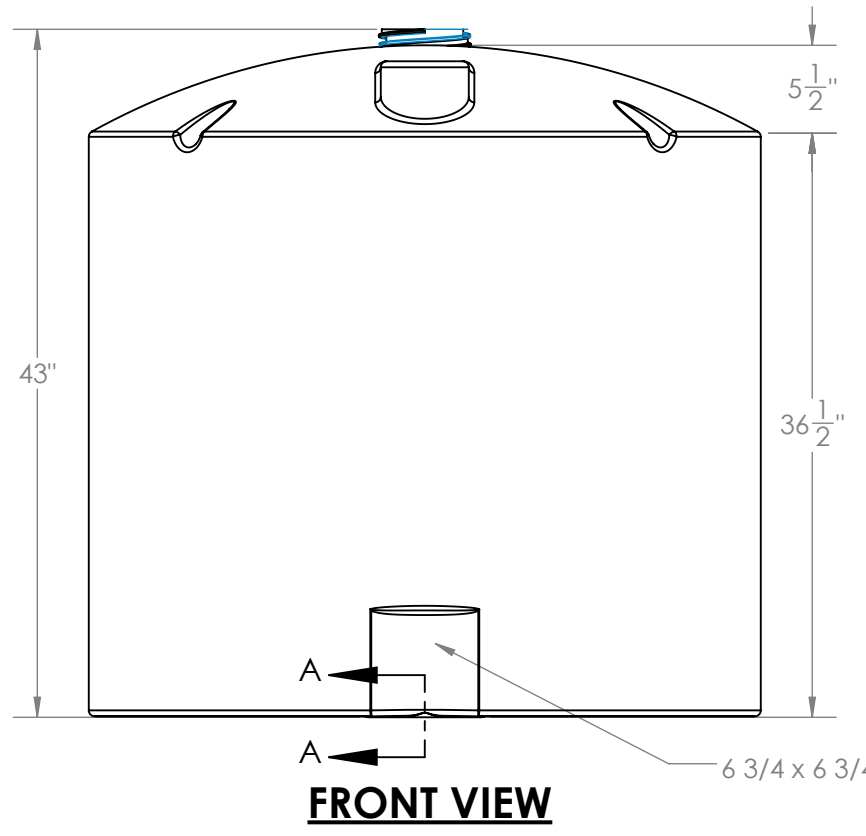
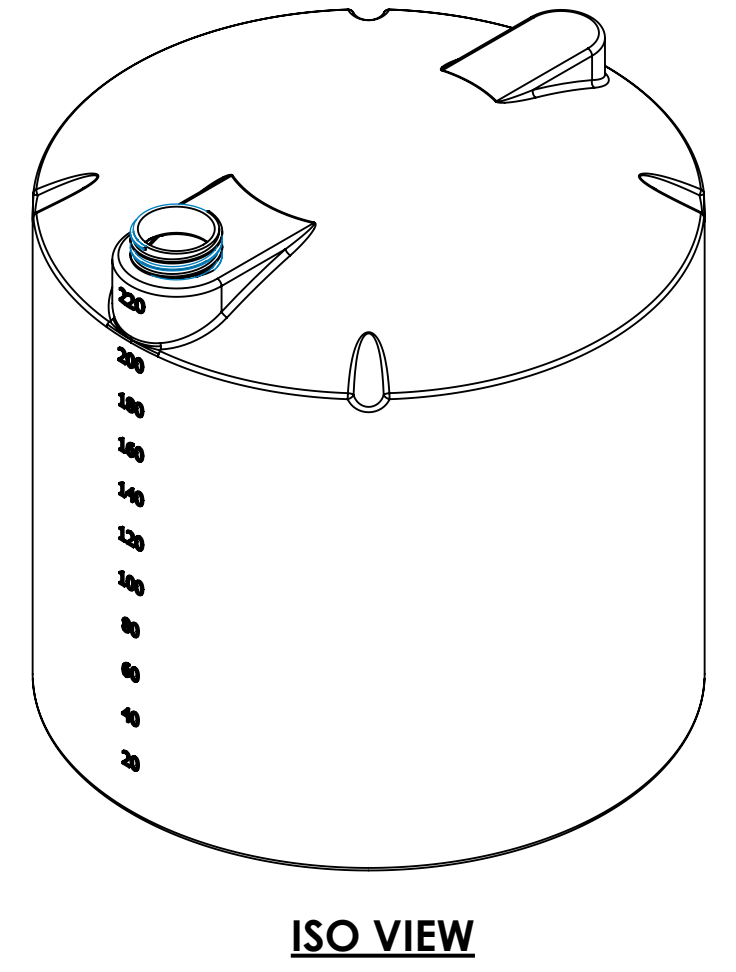
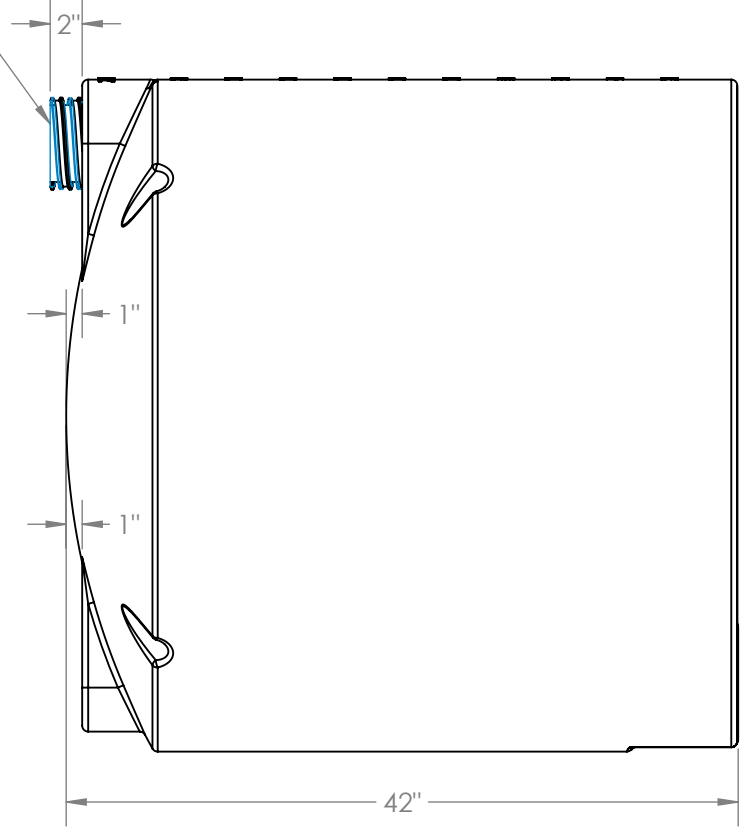

**STANDARD SPECS:**  
5" FILL OPENING,  
(1) 1-1/4" POLYPROPYLENE FITTING  
IN STANDARD LOCATIONS

**PROPRIETARY AND CONFIDENTIAL**  
THE INFORMATION CONTAINED IN THIS DRAWING IS THE SOLE PROPERTY OF PEABODY ENGINEERING. ANY REPRODUCTION IN PART OR AS A WHOLE WITHOUT THE WRITTEN PERMISSION OF PEABODY ENGINEERING IS PROHIBITED.

UNLESS OTHERWISE SPECIFIED:

DIMENSIONS ARE IN INCHES  
TOLERANCES:  
FRACTIONAL ± 1/8"  
ONE PLACE DECIMAL ± .25"  
TWO PLACE DECIMAL ± .125"  
THREE PLACE DECIMAL ± .063"

TANK MATERIAL:  
**HDPE**

INNER TANK S/N:  
-

OUTER TANK S/N:  
-

CUSTOMER PO#  
-

DO NOT SCALE DRAWING

NAME	DATE
DRAWN NBH	6/9/16
CHECKED	
ENG APPR.	
MFG APPR.	
Q.A.	
COMMENTS:	

		PROJECT:	-
		CUSTOMER:	PEABODY STANDARD
SITE/LOCATION:		FOB: OH, GA, OK, NY, IA, CA, TX	
DRAWING#:			
SIZE	DESC.	REV.	
<b>B</b>	220 GA VERTICAL TANK Ø42" x 44"		
SCALE: 1:12		SHEET 1 OF 1	