

TOP VIEW

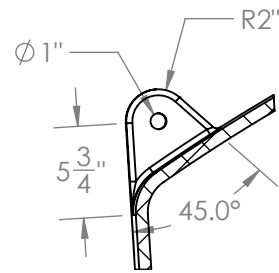

SECTION A-A
SCALE 1 : 12

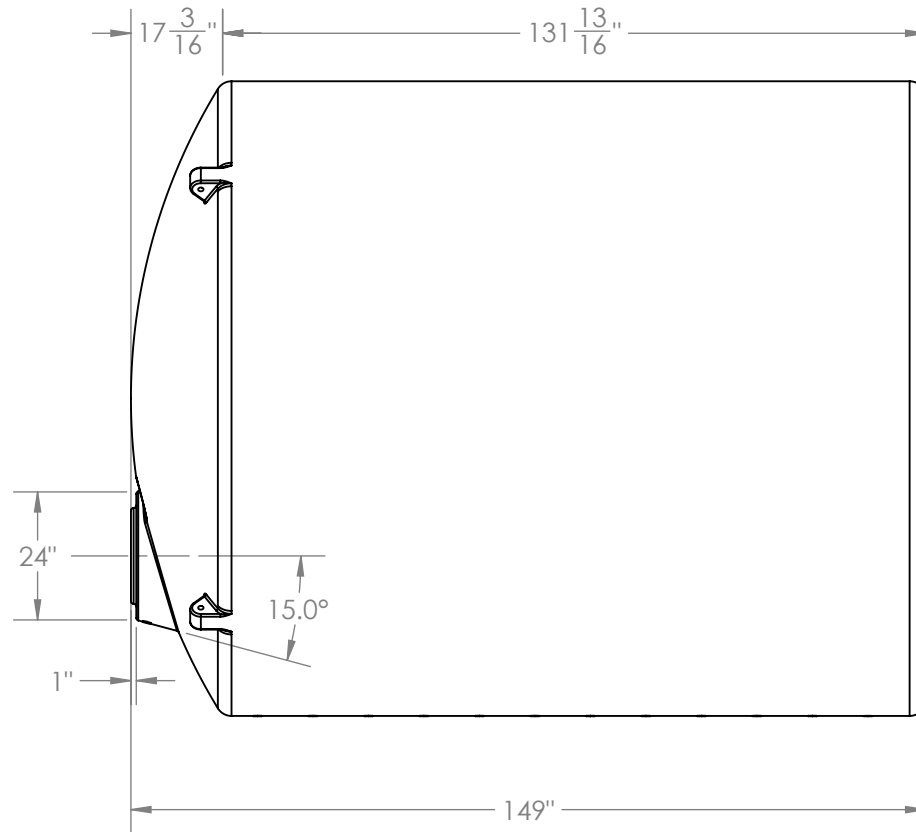

SIDE VIEW

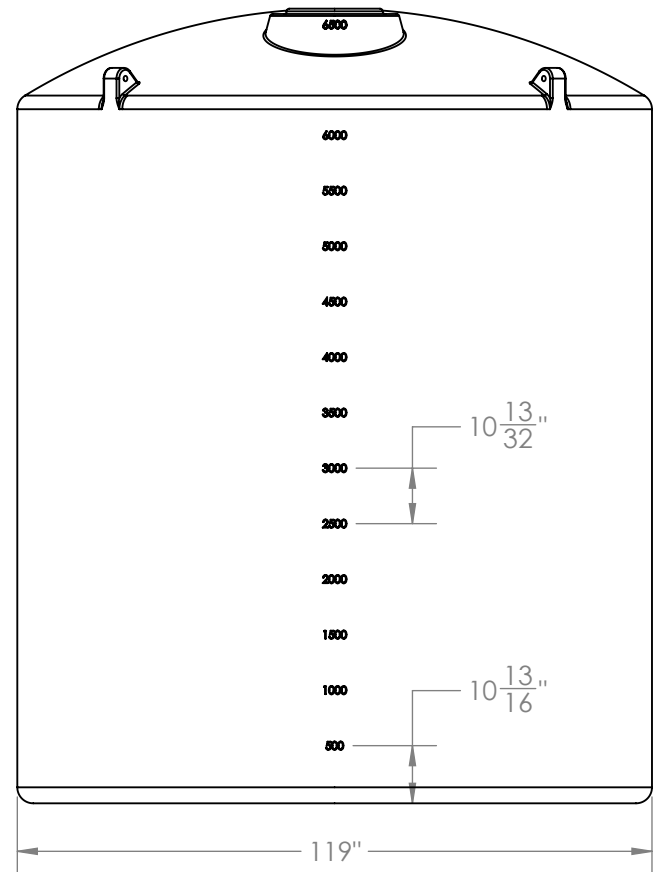

FRONTVIEW

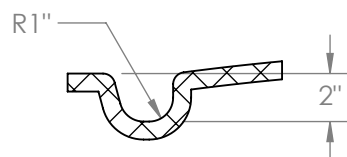

SECTION B-B
SCALE 1 : 8

STANDARD SPECS:
16" FILL OPENING,
(1) 3" POLYPROPYLENE FITTING
WITH 2" REDUCER & SIPHON TUBE
IN STANDARD LOCATIONS

PROPRIETARY AND CONFIDENTIAL
THE INFORMATION CONTAINED IN THIS
DRAWING IS THE SOLE PROPERTY OF
PEABODY ENGINEERING. ANY
REPRODUCTION IN PART OR AS A WHOLE
WITHOUT THE WRITTEN PERMISSION OF
PEABODY ENGINEERING IS
PROHIBITED.

UNLESS OTHERWISE SPECIFIED:

DIMENSIONS ARE IN INCHES
TOLERANCES:
FRACTIONAL ± 1/8"
ONE PLACE DECIMAL ± .25"
TWO PLACE DECIMAL ± .125"
THREE PLACE DECIMAL ± .063"

TANK MATERIAL:
HDPE

INNER TANK S/N:

OUTER TANK S/N:

CUSTOMER PO#

DO NOT SCALE DRAWING

	NAME	DATE
DRAWN	NBH	6/21/16
CHECKED		
ENG APPR.		
MFG APPR.		
Q.A.		
COMMENTS:		

PROJECT:		PEABODY engineering	
SITE/LOCATION:		FOB: CA	
DRAWING#:			
SIZE	DESC.	REV.	
B	6500 GA VERTICAL TANK Ø119" x 150"		
SCALE: 1:36		SHEET 1 OF 1	