

RED CAPLUG/ O-RING SUB-ASSEMBLY

Ø2" SPIN WELD FITTING AND PLUG

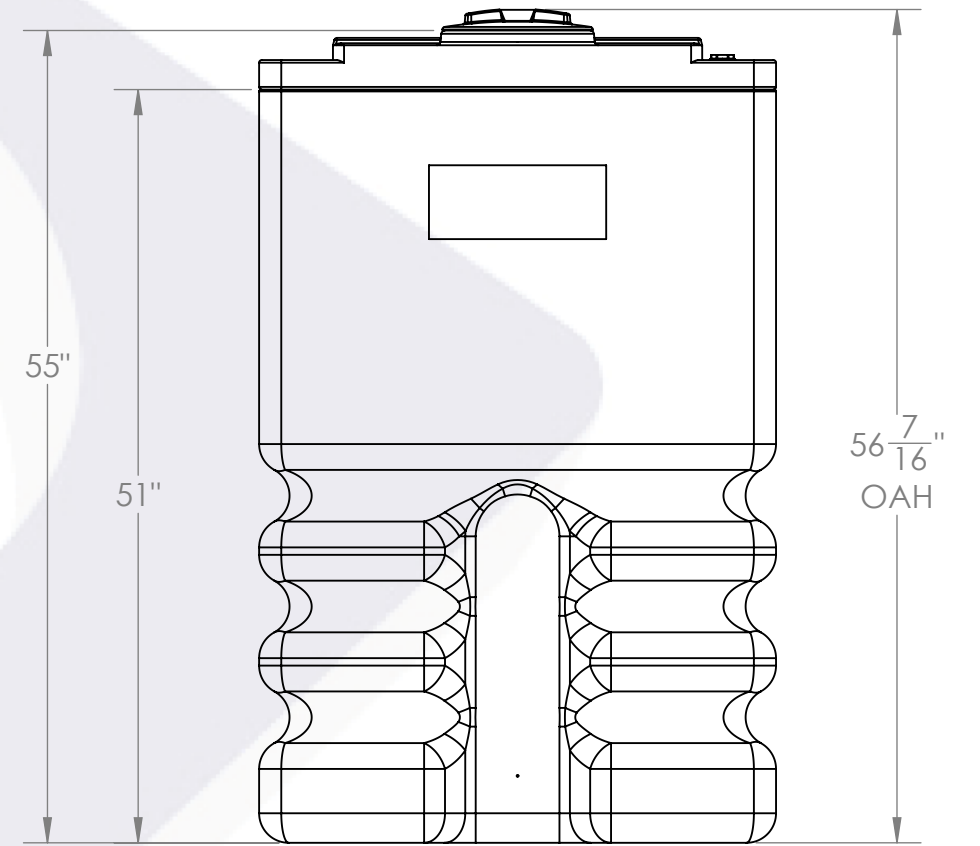
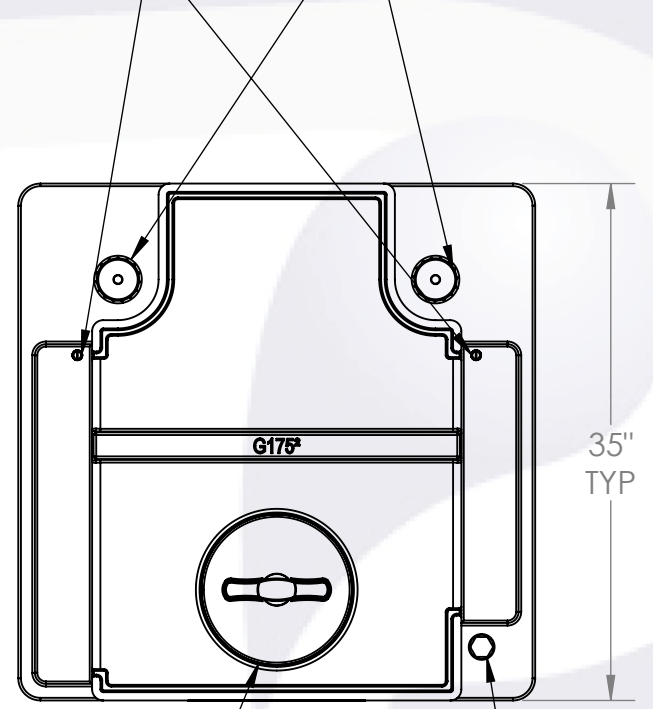

8" LID WITH MOLDED IN THREADS

1" INTERSISTIAL, MOLDED-IN THREADS AND RAISED

NOTES:

1. CAPACITY: 175 GAL. NOMINAL
2. TANK MATERIAL: LLDPE
3. SERVICE PRESSURE: ATMOSPHERIC
4. NSF/ANSI STANDARD 61 CERTIFIED
5. AVAILABLE W/ FRP WRAP
CONTACT CUSTOMER SERVICE FOR ADDITIONAL INFORMATION

PROPRIETARY AND CONFIDENTIAL
THE INFORMATION CONTAINED IN THIS DRAWING IS THE SOLE PROPERTY OF PEABODY ENGINEERING. ANY REPRODUCTION IN PART OR AS A WHOLE WITHOUT THE WRITTEN PERMISSION OF PEABODY ENGINEERING IS PROHIBITED.

UNLESS OTHERWISE SPECIFIED:		NAME	DATE			
DIMENSIONS ARE IN INCHES TOLERANCES: ±1/4" ANGULAR: ± .5° ONE PLACE DECIMAL: ± .25 TWO PLACE DECIMAL: ± .125 THREE PLACE DECIMAL: ± .063		DRAWN	AAF 08/13/18			
TANK MATERIAL:	LLDPE	CHECKED		PROJECT:	GEMINI ²	
INNER TANK S/N:		ENG APPR.		CUSTOMER:	PEABODY STANDARD	
OUTER TANK S/N:		MFG APPR.		SITE/LOCATION:	FOB: CORONA, CA	
CUSTOMER PO#		Q.A.		SALES ORDER:	-	
DO NOT SCALE DRAWING		ALTERNATIVE VERSIONS		SIZE	DESC.	REV.
		MATERIALS: XLPE, PPL, PVDF COLORS: NATURAL, BLUE OR BLACK AVAILABLE WITH FRP WRAP		B	175 GAL GEMINI² TANK 35" x 35"	1
		CALL FOR PART NUMBERS		SCALE: 1:13	SHEET 1 OF 1	