

D
C
B
A

D
C
B
A

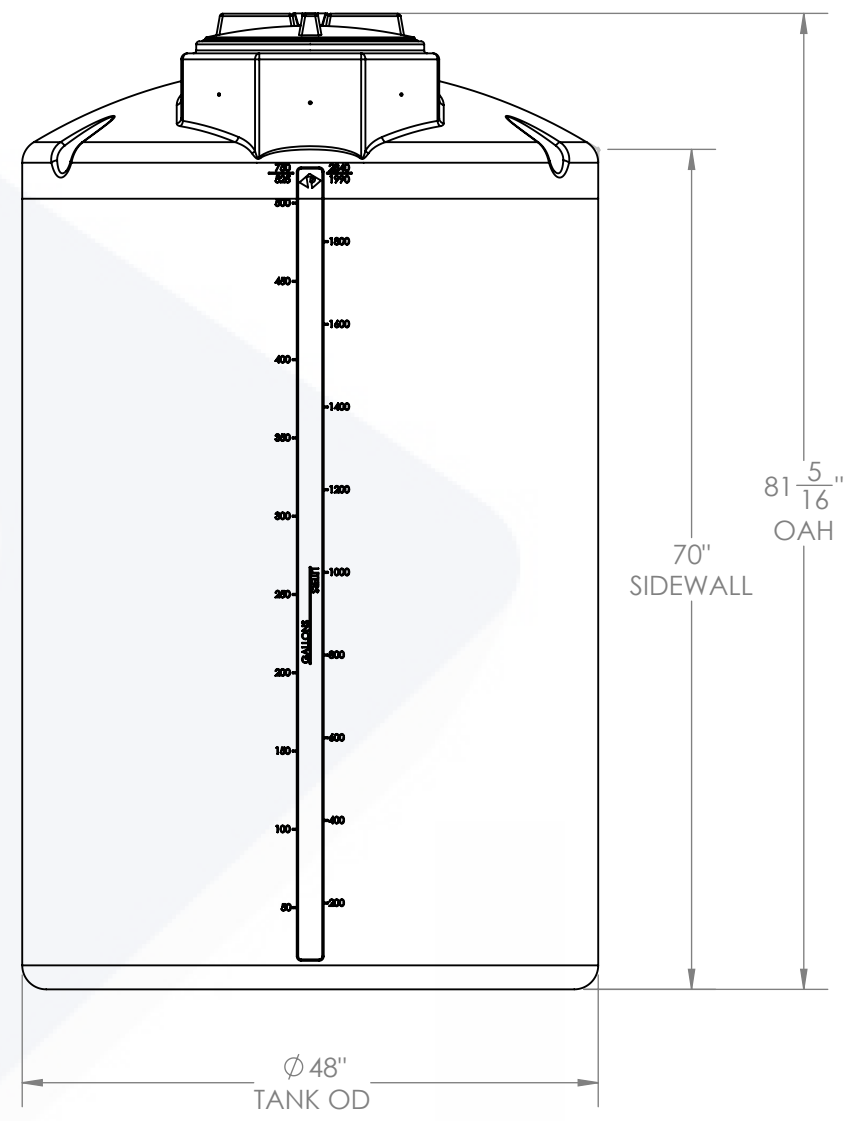
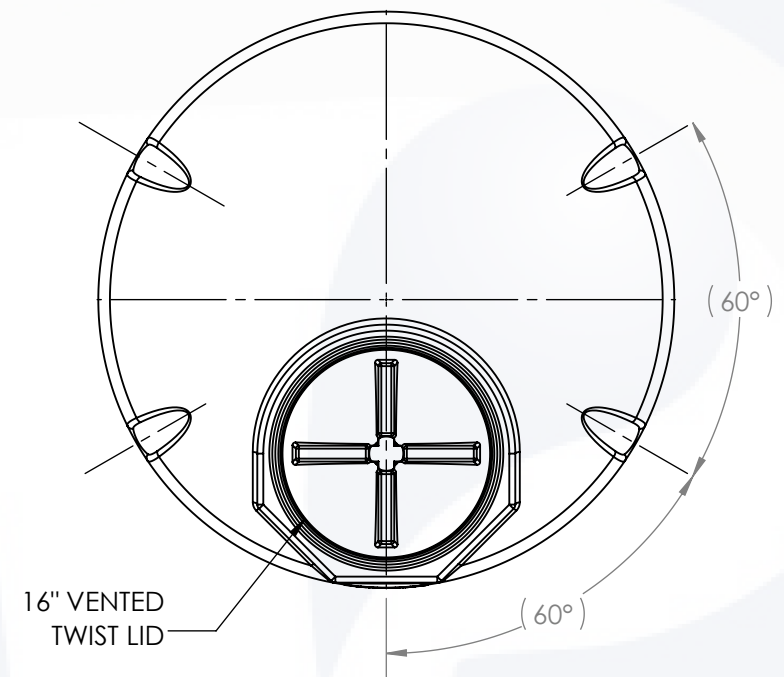
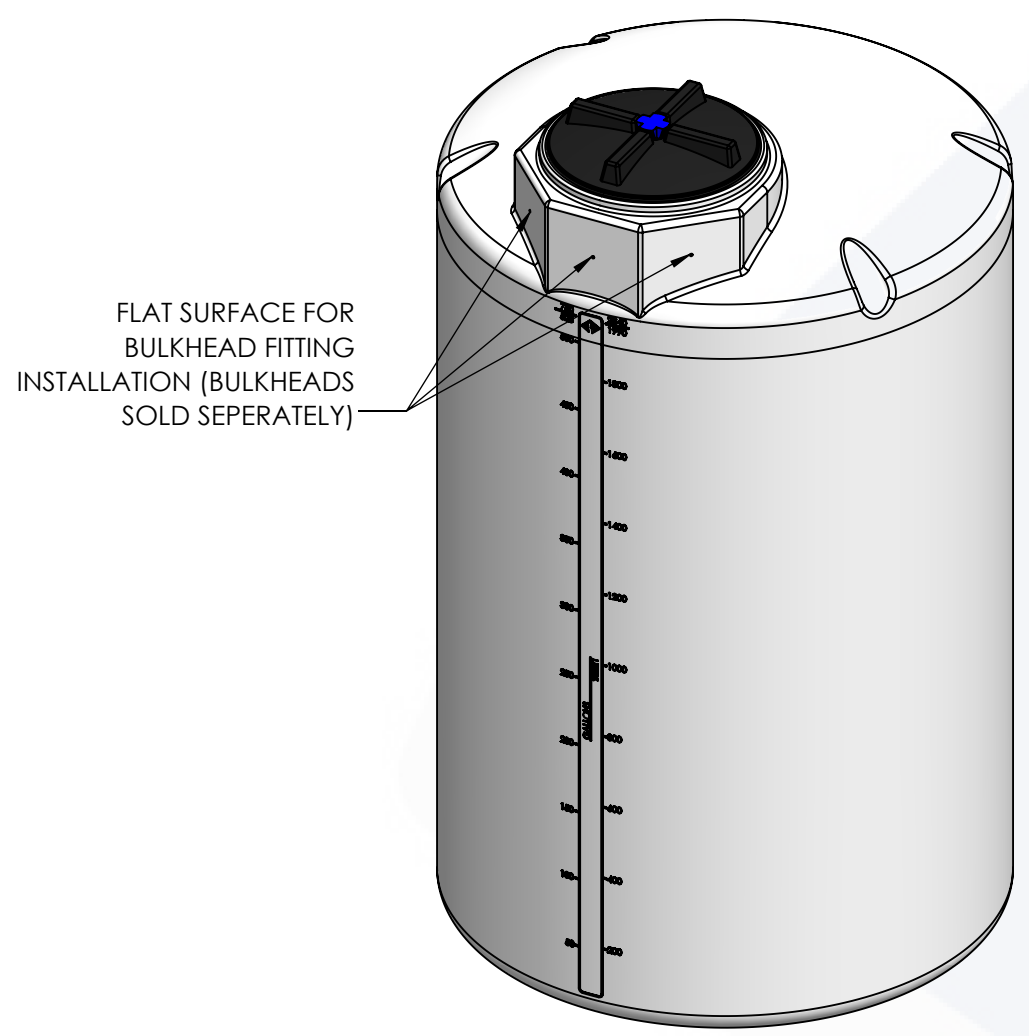

NOTES:

1. CAPACITY: 525 GAL. NOMINAL
2. TANK MATERIAL OPTIONS:
LLDPE HDLPE XLPE FDA WATER PPL PVDF
3. SERVICE PRESSURE: ATMOSPHERIC
4. NSF/ANSI STANDARD 61 CERTIFIED
5. AVAILABLE W/ FRP WRAP
CONTACT CUSTOMER SERVICE FOR ADDITIONAL INFORMATION

PROPRIETARY AND CONFIDENTIAL
THE INFORMATION CONTAINED IN THIS DRAWING IS THE SOLE PROPERTY OF PEABODY ENGINEERING. ANY REPRODUCTION IN PART OR AS A WHOLE WITHOUT THE WRITTEN PERMISSION OF PEABODY ENGINEERING IS PROHIBITED.

UNLESS OTHERWISE SPECIFIED:		NAME	DATE							
DIMENSIONS ARE IN INCHES TOLERANCES: ±1/4" ANGULAR: ±.5° ONE PLACE DECIMAL: ±.25 TWO PLACE DECIMAL: ±.125 THREE PLACE DECIMAL: ±.063		DRAWN	RFR 07/09/18							
TANK MATERIAL:	LLDPE	CHECKED		PROJECT: PROCHEM® PROCESS CHEMICAL TANKS						
INNER TANK S/N:		ENG APPR.		CUSTOMER: PEABODY STANDARD						
OUTER TANK S/N:		MFG APPR.		SITE/LOCATION: FOB: CORONA, CA						
CUSTOMER PO#		Q.A.		SALES ORDER: -						
DO NOT SCALE DRAWING				<table border="1"> <tr> <td>SIZE</td> <td>DESC.</td> <td>REV.</td> </tr> <tr> <td>B</td> <td>525 GAL PROCHEM® TANK, Ø48" x 82"</td> <td>A</td> </tr> </table>	SIZE	DESC.	REV.	B	525 GAL PROCHEM® TANK, Ø48" x 82"	A
SIZE	DESC.	REV.								
B	525 GAL PROCHEM® TANK, Ø48" x 82"	A								
				SCALE: 1:16 SHEET 1 OF 1						