

8 7 6 5 4 3 2 1

D
C
B
A

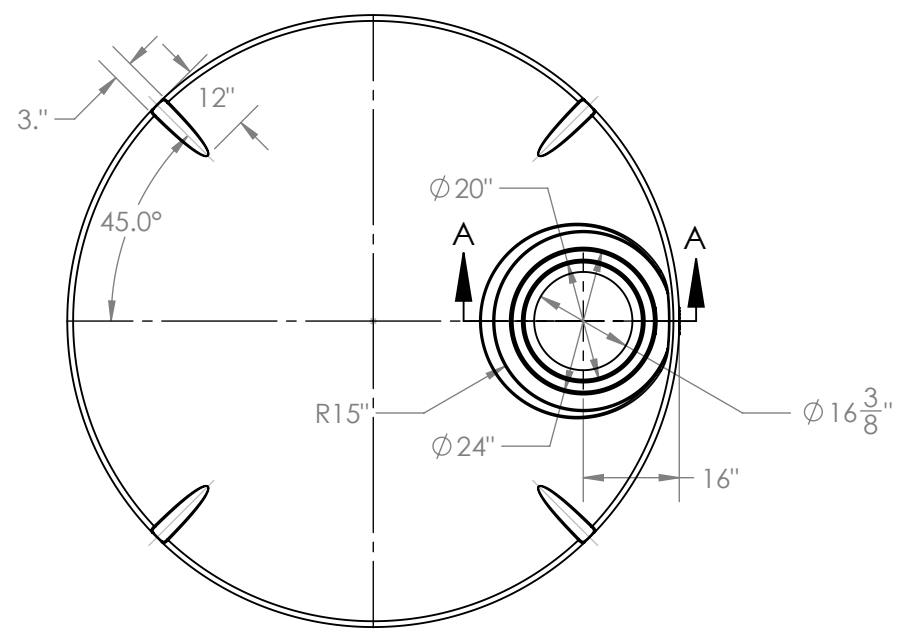

TOP VIEW

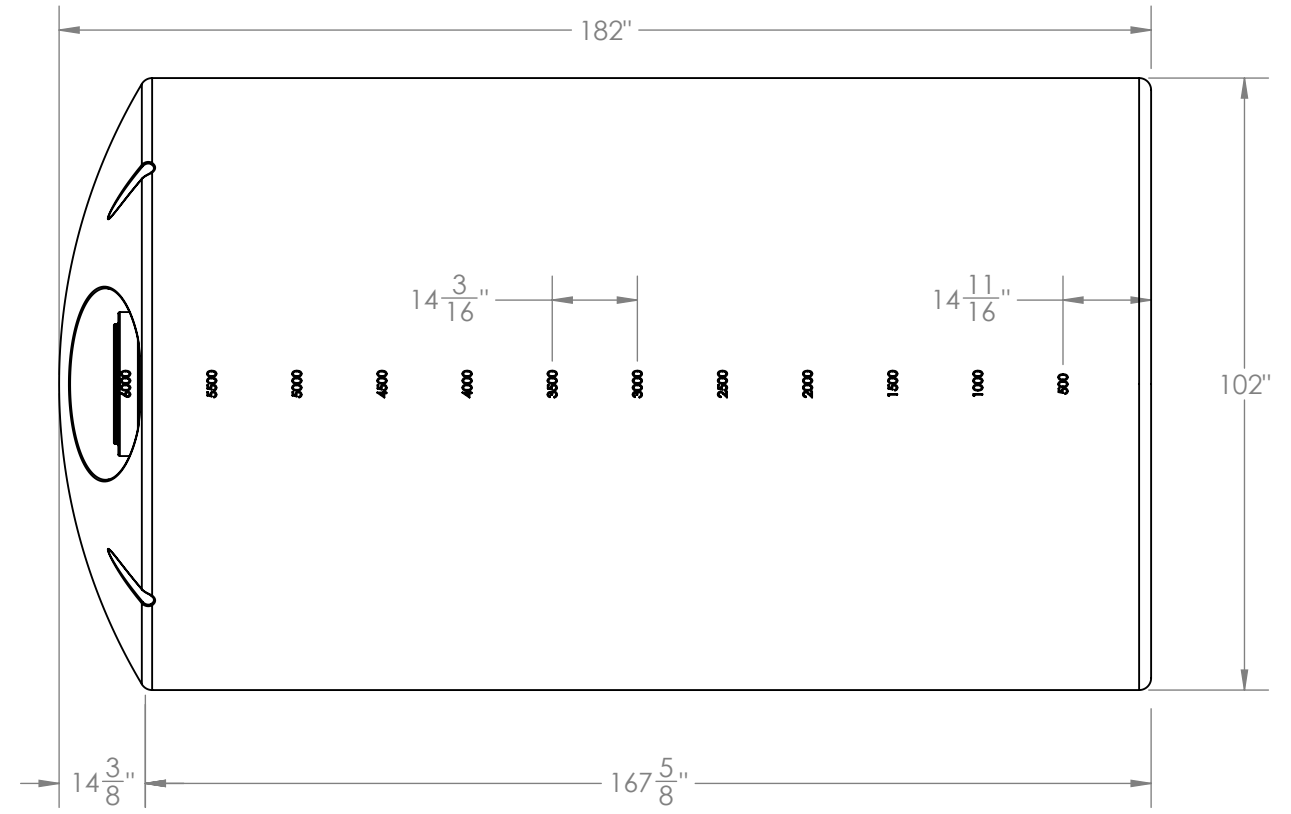

FRONT VIEW

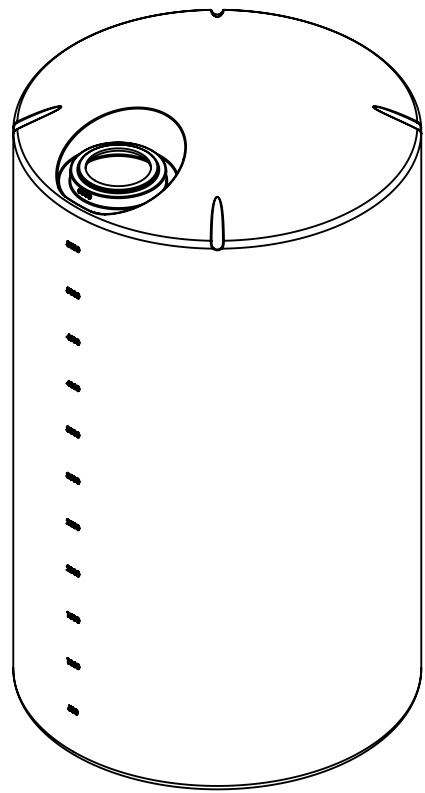

ISO VIEW
SCALE 1:48

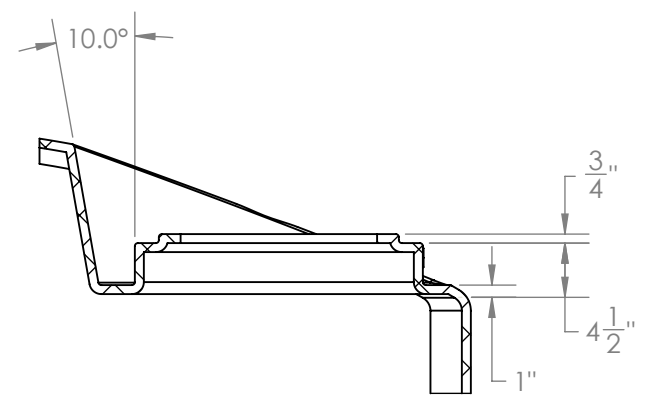

SECTION A-A
SCALE 1:16

STANDARD SPECS:
16" FILL OPENING,
(1) 3" POLYPROPYLENE FITTING
WITH 2" REDUCER & SIPHON TUBE
IN STANDARD LOCATIONS

PROPRIETARY AND CONFIDENTIAL
THE INFORMATION CONTAINED IN THIS
DRAWING IS THE SOLE PROPERTY OF
PEABODY ENGINEERING. ANY
REPRODUCTION IN PART OR AS A WHOLE
WITHOUT THE WRITTEN PERMISSION OF
PEABODY ENGINEERING IS
PROHIBITED.

UNLESS OTHERWISE SPECIFIED:
DIMENSIONS ARE IN INCHES
TOLERANCES:
FRACTIONAL ± 1/8"
ONE PLACE DECIMAL ± .25"
TWO PLACE DECIMAL ± .125"
THREE PLACE DECIMAL ± .063"

TANK MATERIAL:
HDPE

INNER TANK S/N:
-

OUTER TANK S/N:
-

CUSTOMER PO#
-

DO NOT SCALE DRAWING

NAME	DATE
DRAWN NBH	6/21/16
CHECKED	
ENG APPR.	
MFG APPR.	
Q.A.	
COMMENTS:	



PROJECT:		-
CUSTOMER:		PEABODY STANDARD
SITE/LOCATION:		FOB: MN, CA
DRAWING#:		
SIZE	DESC.	REV.
B	6000 GA VERTICAL TANK Ø102" x 182"	
SCALE: 1:32		SHEET 1 OF 1

8 7 6 5 4 3 2 1