

D
C
B
A

D
C
B
A

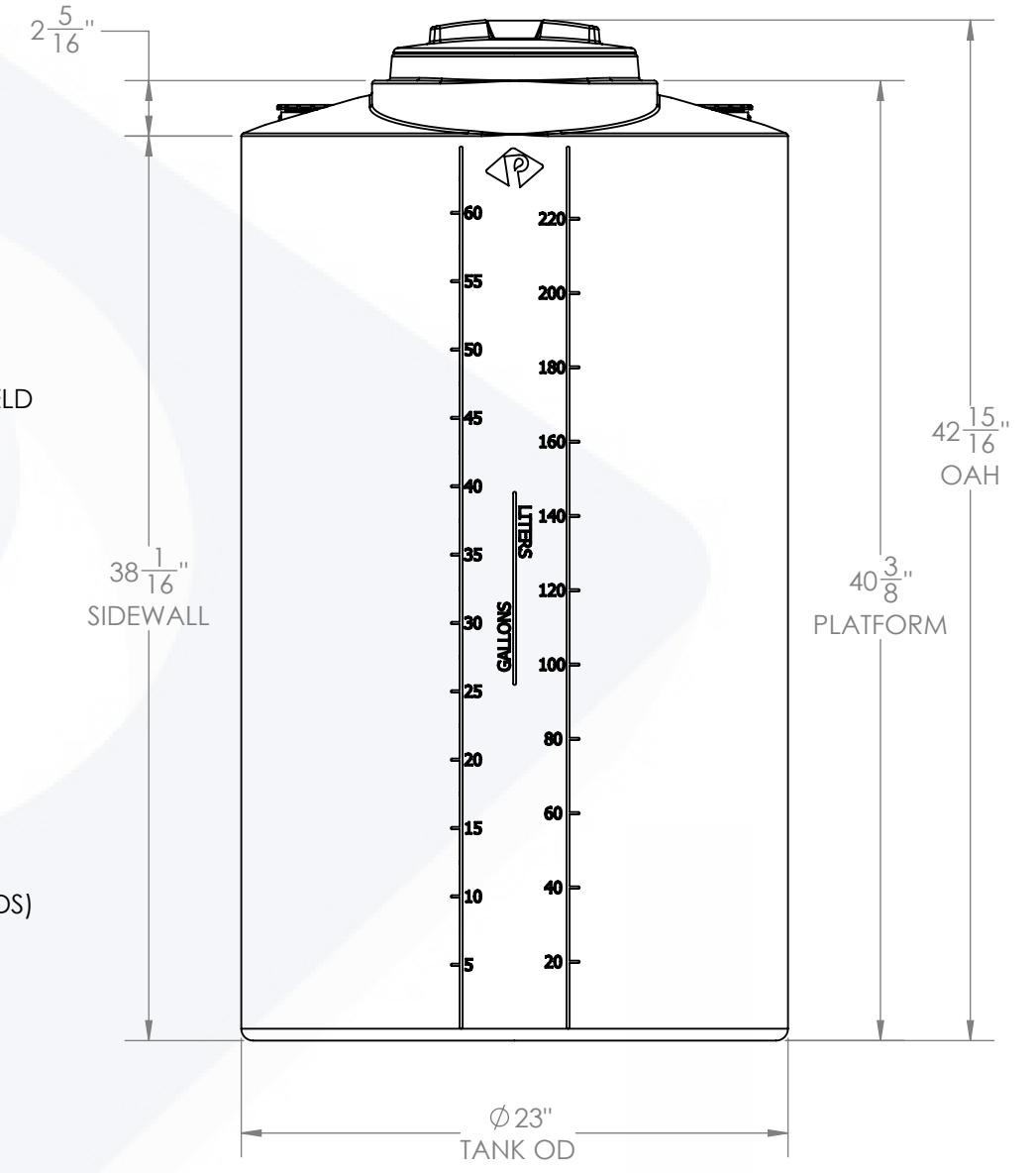
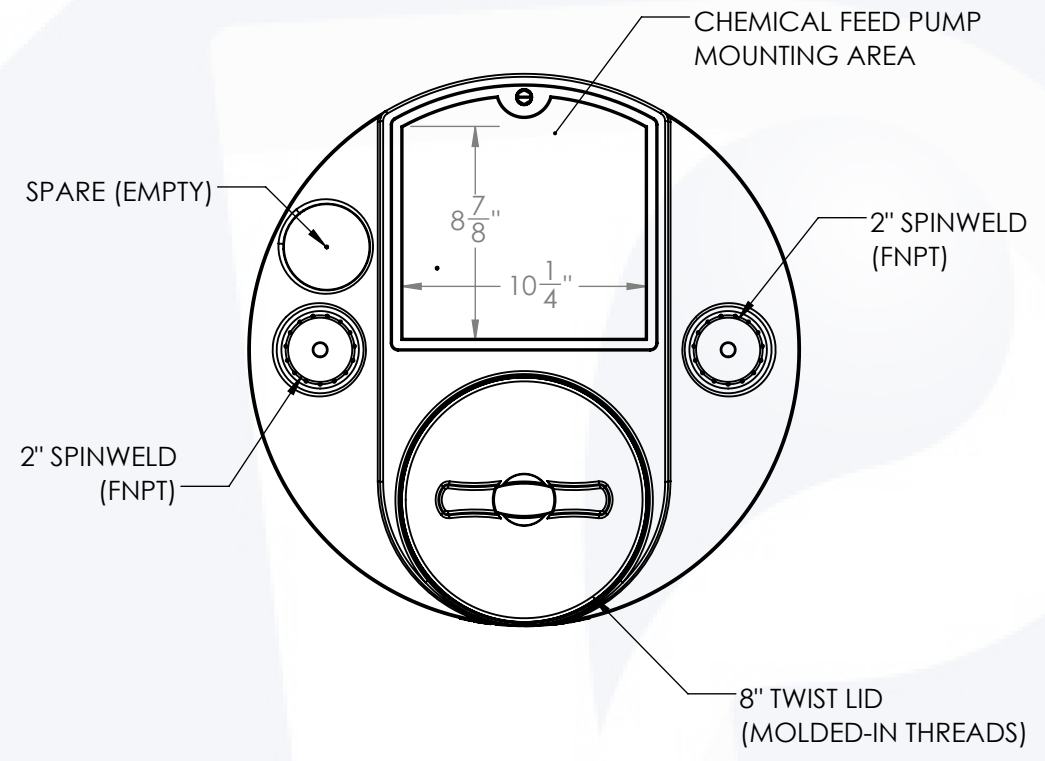
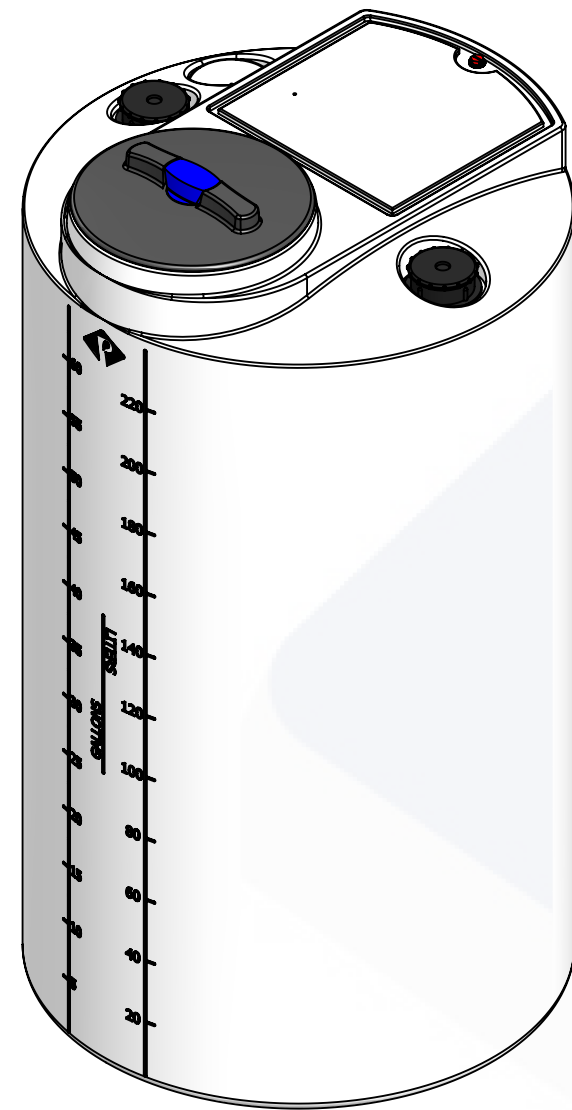

- NOTES:**
- CAPACITY: 65 GAL. NOMINAL
 - TANK MATERIAL OPTIONS:
3. LLDPE HDLPE XLPE FDA WATER PPL PVDF
 - SERVICE PRESSURE: ATMOSPHERIC
 - NSF/ANSI STANDARD 61 CERTIFIED
 - AVAILABLE W/ FRP WRAP
 - CONTACT CUSTOMER SERVICE FOR ADDITIONAL INFORMATION

PROPRIETARY AND CONFIDENTIAL
THE INFORMATION CONTAINED IN THIS DRAWING IS THE SOLE PROPERTY OF PEABODY ENGINEERING. ANY REPRODUCTION IN PART OR AS A WHOLE WITHOUT THE WRITTEN PERMISSION OF PEABODY ENGINEERING IS PROHIBITED.

UNLESS OTHERWISE SPECIFIED:		NAME	DATE			
DIMENSIONS ARE IN INCHES TOLERANCES: ±1/4" ANGULAR: ±.5° ONE PLACE DECIMAL: ±.25 TWO PLACE DECIMAL: ±.125 THREE PLACE DECIMAL: ±.063		DRAWN	RFR 08/08/17			
TANK MATERIAL:	LLDPE	CHECKED		PROJECT:	PROCHEM® TANKS	
INNER TANK S/N:		ENG APPR.		CUSTOMER:	PEABODY STANDARD	
OUTER TANK S/N:		MFG APPR.		SITE/LOCATION:	FOB: CORONA, CA	
CUSTOMER PO#		Q.A.		SALES ORDER:	-	
DO NOT SCALE DRAWING				SIZE	DESC.	REV.
				B	65 GAL PROCHEM® TANK, Ø23" x 43"	A
				SCALE: 1:8	SHEET 1 OF 1	